

## ECS40

### Series PEEK™ Electrodeless Conductivity Sensors

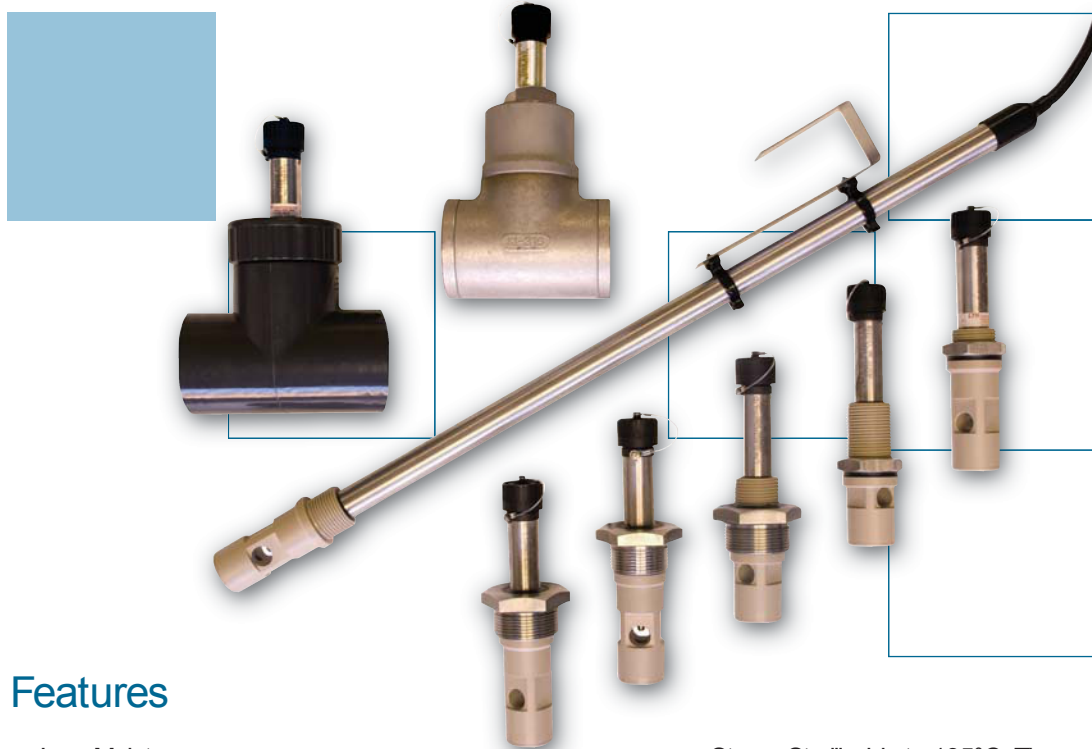

### Features

- Low Maintenance.
- Hygienic, Inline, Dip and Tank Mounting Options.
- Ideal for Brewing, Dairy, Food and Process Applications.
- Conductivity and Solution Concentration Measurements.
- Steam Sterilisable to 135°C, Thermal Shock Resistant.
- IP67 Connection Simplifies Installation and Maintenance.
- Fast Temperature Response  $t_{90} < 10$  secs

The Electrodeless method of measuring conductivity has many advantages over conventional methods.

In particular the sensors will operate with virtually zero maintenance and provide reliable measurements over extended time periods.

The ECS40 sensors can be mounted inline, in a tank wall, large bore pipe or in an open tank using a variety of fittings. The option of several different hygienic flanges caters for the majority of applications.

The sensor is manufactured in PEEK™ a food grade material with excellent chemical resistance and high temperature performance. The construction of the sensor allows it to operate at 100°C continuously, withstand thermal shocks commonly associated with CIP applications and the sensor can be steam sterilised up to 135°C.

The sensors are fitted with Pt1000 temperature sensors and are compatible with all LTH Electrodeless conductivity instruments. The temperature sensor is mounted in direct contact with the medium via a stainless steel jacket with an alternative PEEK jacket available for applications where stainless steel might be unacceptable. Connection is made via an IP67 plug which simplifies installation and maintenance.

## ECS/42T

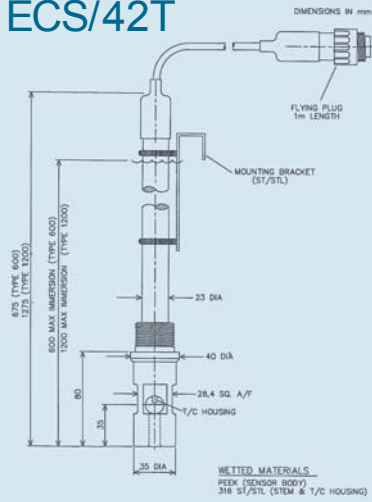

## ECS/43T

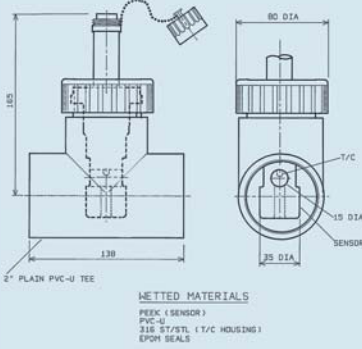

## ECS/44T

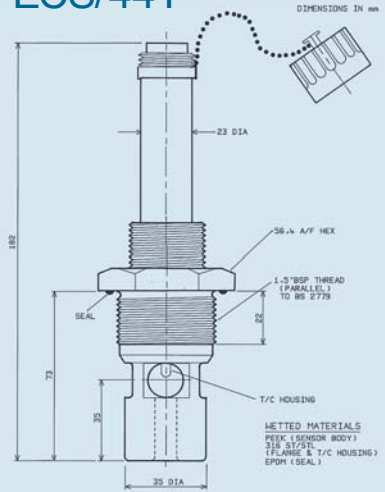

## ECS/45T

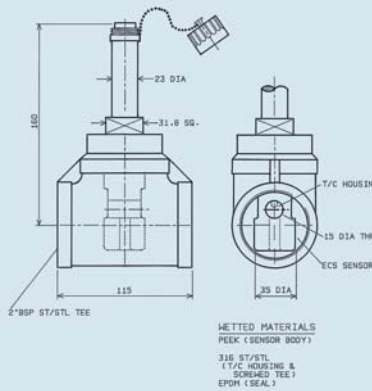

## ECS/46T

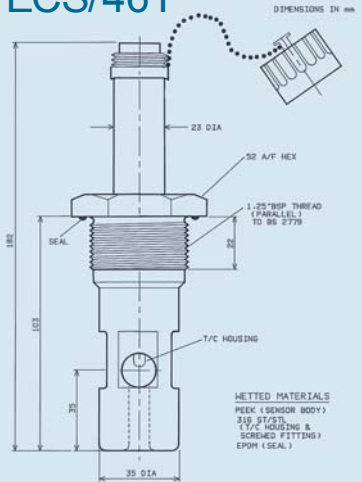

## ECS/47T

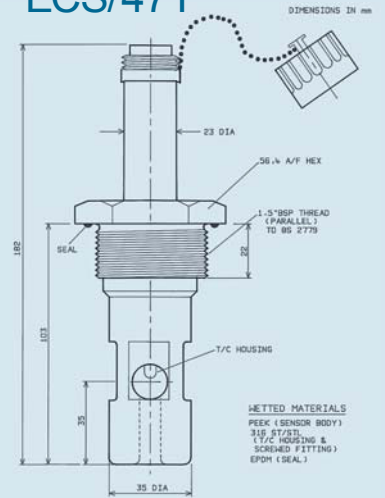

## ECS/48T

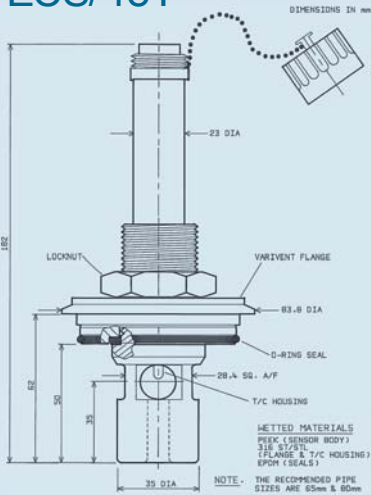

## ECS/49T

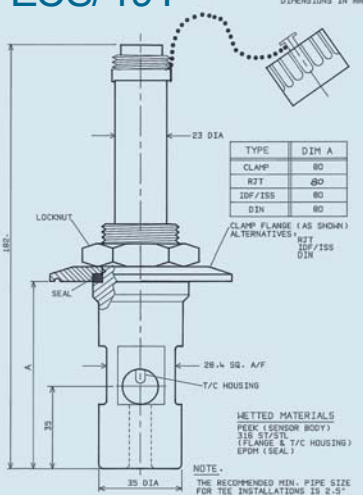

## Cable Options

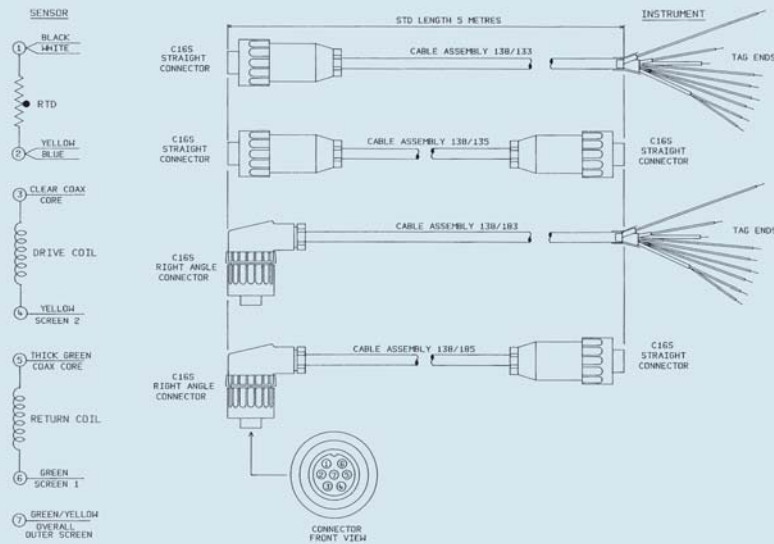

Cable Assembly 138/332

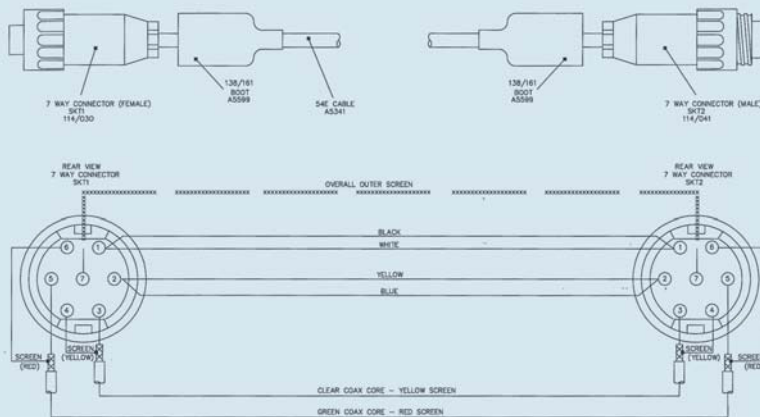

## Specification

Hygienic Flanges

Standard Sizes

Temperature:

RJT: 2", 2.5", 3"  
Tri clamp: 2", 3"  
IDF/ISS: 2", 2.5", 3"  
DIN 1185: 50mm, 80 mm

Maximum continuous, 100°C,  
subject to material compatibility  
with solution. Short term  
30 mins 135°C.

Suffix T

Common Specification

Thermal shock:

Temperature sensor: Class A Pt1000 RTD

Response T90

10°C per second.  
Less than 10s – stainless steel  
temperature pocket.  
Less than 2.5 mins – PEEK  
temperature pocket.

**Notes:** Flanges for the ECS49 sensors must be ordered separately. Minimum pipe size for insertion sensors 2.5", 63.5mm. Optional PEEK temperature pocket available. Temperature, pressure and solution composition will influence the life expectancy of the measurement sensor. Varivent® is the registered trademark of Tuchenhausen GmbH.

## Order Codes

### ECS40 Series Electrodeless Conductivity Sensor Connection Cables

Type No	Part No	Description
54E/C16	138/133	5 metres of type 54E Electrodeless conductivity sensor cable fitted with C16P connector.
54E/C16	138/320	10 metres of type 54E Electrodeless conductivity sensor cable fitted with C16P connector.
54E/C16	138/321	15 metres of type 54E Electrodeless conductivity sensor cable fitted with C16P connector.
54E/C16	138/324	20 metres of type 54E Electrodeless conductivity sensor cable fitted with C16P connector.
54E/C16	138/325	30 metres of type 54E Electrodeless conductivity sensor cable fitted with C16P connector.
54E/C16	138/332	5 metre Conductivity sensor connection cable for use with wall mounting HET63 conductivity transmitter.
54E/C16	138/333	10 metre Conductivity sensor connection cable for use with wall mounting HET63 conductivity transmitter.

\*Other cable lengths available on request, please contact our sales department for further details.

### ECS40 Series PEEK Electrodeless Conductivity Sensors. Cables to be ordered separately

Type No	Part No	Description
ECS42T	8515	600mm PEEK DIP Electrodeless conductivity sensor with temperature compensation and stainless steel dip tube. Fitted with 0.5m of cable & C16 connector. Wetted materials PEEK & stainless steel.
ECS42T	8516	1200mm PEEK Dip Electrodeless conductivity sensor with temperature compensation and stainless steel dip tube. Fitted with 0.5m of cable & C16 connector. Wetted materials PEEK & stainless steel.
ECS43T	8523	Inline Electrodeless conductivity sensor supplied in a 2" BSP PVC Tee with PT1000 temperature compensation. Wetted materials PEEK, 316 Stainless Steel, PVC, Viton O Ring. Maximum temperature: 60°C, Maximum pressure: 100psi (6.5 Bar).
ECS/44T	8529	1.5" BSP Male threaded Short PEEK Electrodeless conductivity sensor. Wetted materials PEEK, 316 Stainless Steel & Viton O ring. Maximum temperature: 100°C, Maximum pressure: 150psi (10 Bar).
ECS/44T PK/PP	8518	ECS/44T 1.5" BSP Male threaded Short PEEK Electrodeless conductivity sensor with Polypropylene adaptor & PEEK temperature pocket. Wetted materials PEEK, 316 Stainless Steel & Viton O ring. Maximum temperature: 90°C, Maximum pressure: 100psi (6.5 Bar).
ECS45T	8525	Inline PEEK Electrodeless conductivity sensor supplied in a 2" BSP 316 Stainless Steel tee. Wetted materials PEEK, 316 Stainless Steel, Viton O Ring. Maximum temperature: 100°C, Maximum pressure: 100psi (6.5 Bar).
ECS46T	8524	1.25" BSP Male threaded insertion PEEK Electrodeless conductivity sensor. Wetted materials PEEK, 316 Stainless Steel & Viton O ring. Maximum temperature: 100°C, Maximum pressure: 150psi (10 Bar).
ECS47T	8526	1.5" BSP Male threaded insertion PEEK Electrodeless conductivity sensor. Wetted materials PEEK, 316 Stainless Steel & Viton O ring. Maximum temperature: 100°C, Maximum pressure: 150psi (10 Bar).
ECS/47T PK/PP	8519	ECS/47T 1.5" BSP Male threaded PEEK Electrodeless conductivity sensor with Polypropylene adaptor & PEEK temperature pocket. Maximum temperature: 90°C, Maximum pressure: 100psi (6.5 Bar).
ECS48T	8528	PEEK Electrodeless conductivity sensor for use with a Varivent flange, or one of the other hygienic flange kits. Wetted materials PEEK, 316 Stainless Steel and Viton seal. Maximum temperature: 100°C, Maximum pressure: 100psi (6.5 Bar).
ECS49T	8527	PEEK Electrodeless conductivity sensor for use with one of the hygienic flange kits. Wetted materials PEEK, 316 Stainless Steel and Viton seal. Maximum temperature: 100°C, Maximum pressure: 100psi (6.5 Bar).
ECS/49T	8534	Peek Electrodeless Conductivity Sensor with PEEK temperature pocket for use with sanitary flange kits. The sensor is fitted with PT1000 temperature compensation & C16 connection plug. Wetted materials PEEK, 316 stainless steel, Viton seal. Maximum temperature: 100°C, Maximum pressure: 100psi (6.5 Bar).



These products comply with current European Directives